

Planar and Pyramidal Tetracoordinate Carbon in Organoboron Compounds

Ruslan M. Minyaev,* Tatyana N. Gribanova, Vladimir I. Minkin,* and Andrey G. Starikov

Institute of Physical and Organic Chemistry at Rostov State University, Southern Research Center of Russian Academy of Sciences, Rostov-on-Don, Russian Federation

Roald Hoffmann*

Department of Chemistry and Chemical Biology, Cornell University, Ithaca, New York, 14853-1301

minkin@ipoc.rsu.ru; minyaev@ipoc.rsu.ru; rh34@cornell.edu

Received April 3, 2005

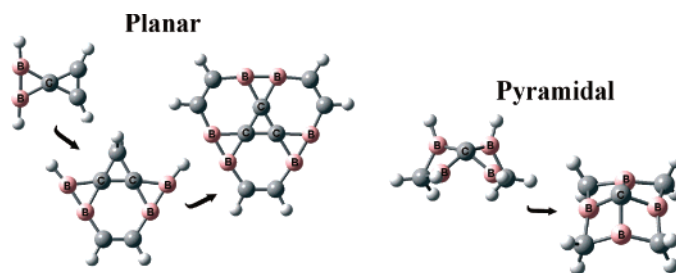

Using previously proposed $C(BH)_2(CH)_2$ (**16**, **17**) and $C(CH)_2B_2$ (**22**) systems with a central planar tetracoordinate carbon (ptC) atom linking two three-membered rings as building blocks, a series of stable structures containing two and three ptC centers within a molecule have been designed and computationally studied with the DFT (B3LYP/6-311+G**) method. Inclusion of a carbon atom ligated with π -accepting and σ -donating boron centers into at least one aromatic ring is critical for stabilization of a planar structure. A square pyramidal configuration at tetracoordinate carbon may be achieved in appropriately strained molecules such as [3.3.3]tetraborafenestrane **45** and others by surrounding the carbon with boron-centered ligands.

Introduction

The quest for nonclassical structures of organic compounds has taken two directions. The first one is the construction of nonclassical organic compounds containing tetracoordinate carbon atoms in nonstandard (i.e., not tetrahedral, **1**) stereochemical environments.^{1–5} The second direction, closely connected and entangled with the first one, searches for organic compounds containing hypercoordinate carbon centers.^{2,3,8–17} This second approach has been extended to other main-group element compounds with unusual coordination and/or configura-

tion of their bonds.^{2–11} Apart from protonated methanes, in which the coordination number of carbon has been

(1) Hoffmann, R.; Alder, R. G.; Wilcox, C. F., Jr. *J. Am. Chem. Soc.* **1970**, *92*, 4992.

(2) Minkin, V. I.; Minyaev, R. M. *Mendeleev Commun.* **2004**, 43.

(3) Minkin, V. I.; Minyaev, R. M.; Hoffmann, R. *Russ. Chem. Rev.* **2002**, *71*, 869.

(4) Siebert, W.; Gunale, A. *Chem. Soc. Rev.* **1999**, *28*, 367.

(5) (a) Röttger, D.; Erker, G. *Angew. Chem., Int. Ed. Engl.* **1997**, *36*, 812. (b) Dodziuk, H. *Topics In Stereochemistry*; Eliel, E. L., Wilen, S. H.; Wiley and Sons: New York, 1994. (c) Dodziuk, H.; Leszczynski, J.; Nowinski, K. S. *J. Org. Chem.* **1995**, *60*, 6860.

(6) Driess, M.; Aust, J.; Merz, K.; van Wullen, C. *Angew. Chem., Int. Ed.* **1999**, *38*, 3677.

(7) Sahin, Y.; Hartmann, M.; Geiseler, G.; Schweikart, D.; Balzereit, C.; Frenking, G.; Massa, W.; Berndt, A. *Angew. Chem., Int. Ed.* **2001**, *40*, 2662.

(8) Olah, G. A.; Prakash, G. K. S. *Acc. Chem. Res.* **1997**, *30*, 245.

(9) Sorger, K.; Schleyer, P. v. R. *J. Mol. Struct., THEOCHEM* **1995**, *338*, 317.

(10) Minkin, V. I.; Minyaev, R. M.; Zhdanov, Yu. A. *Nonclassical Structures of Organic Compounds*; Mir Publishers: Moscow, 1987.

(11) Olah, G. A.; Prakash, G. K. S.; Williams, R. E. *Hypercarbon Chemistry*; Wiley and Sons: New York, 1987.

(12) (a) Wang, Z.-X.; Schleyer, P. v. R. *Science* **2001**, *292*, 2465. (b) Erhardt, S.; Frenking, G.; Chen, Z.; Schleyer, P. v. R. *Angew. Chem., Int. Ed.* **2005**, *44*, 1078.

(13) Minyaev, R. M.; Gribanova, T. N. *Russ. Chem. Bull.* **2000**, *49*, 783.

(14) Exner, K.; Schleyer, P. v. R. *Science* **2000**, *290*, 1937.

(15) Minyaev, R. M.; Gribanova, T. N.; Starikov, A. G.; Minkin, V. I. *Dokl. Russ. Akad. Nauk* **2002**, *382*, 785.

(16) (a) Minyaev, R. M.; Gribanova, T. N.; Starikov, A. G.; Minkin, V. I. *Mendeleev Commun.* **2001**, 213. (b) Zhai, H.-J.; Alexandrova, A. N.; Birch, K. A.; Boldyrev, A. I.; Wang, L.-S. *Angew. Chem., Int. Ed.* **2003**, *42*, 6004.

(17) Minyaev, R. M.; Minkin, V. I.; Gribanova, T. N. *Mendeleev Commun.* **2004**, 96.

shown to be capable of increases up to seven,⁸ a variety of rather unusual structures with planar penta-,^{12a} hexa-,^{13,14} hepta-,¹⁵ and octacoordinate^{16a} carbon, hepta- and octacoordinate boron,^{16b} silicon,^{16a} and phosphorus^{16a} have been computationally developed. Recently, carborane sandwich systems, in which the central carbon forms multicenter bonds with up to nine neighboring centers, have been predicted to be stable.¹⁷

The nonstandard (nonclassical) topologies of tetracoordinate carbon explored are principally four: planar **2**, pyramidal **3**, inverted (umbrella) **4**, and bisphenoidal (half-planar) **5**. In a spectacular achievement, organic

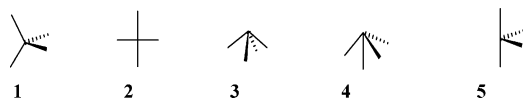

compounds with an inverted, umbrellalike configuration **4** of four bonds at a carbon center, the small propellanes, were predicted and subsequently synthesized by Wiberg and co-workers^{18a} and Eaton and co-workers.^{18b} A carbon bond configuration very close to the bisphenoidal type **5** is observed in a number of carbide clusters and other organometallic compounds^{5,19–21} and was theoretically predicted in tricyclo[2.1.0.0^{1,3}] hexane **6**²² and polyprismanes **7–9**.^{23,24}

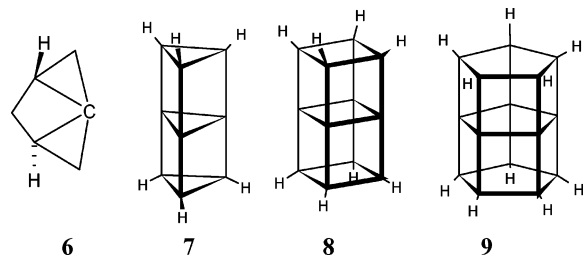

The general strategy of stabilization of a planar tetracoordinate carbon (ptC) center **2**, first put forward by Hoffmann, Alder, and Wilcox,¹ suggested surrounding such a center with π -accepting and σ -donating ligands and its incorporation into aromatic rings. This design has subsequently been complemented by inclusion of a ptC into small rings,²⁵ as well as steric enforcement of the planar orientation of the bonds.^{26–29} Such considerations led to a number of intriguing theoretical predictions (and syntheses) of diverse molecules and ions containing ptC

(18) (a) Wiberg, K. B. *Chem. Rev.* **1989**, *89*, 975. (b) Eaton, P. E.; Temme, G. H. *J. Am. Chem. Soc.* **1973**, *95*, 7508.

(19) Bradley, J. S.; Ansell, G. B.; Leonowicz, M. E.; Hill, E. W. *J. Am. Chem. Soc.* **1981**, *103*, 4968.

(20) Gunale, A.; Pritzkow, H.; Siebert, W.; Steiner, D.; Berndt, A. *Angew. Chem., Int. Ed. Engl.* **1995**, *34*, 1111.

(21) Radius, U.; Silverio, S. J.; Hoffmann, R.; Gleiter, R. *Organometallics* **1996**, *15*, 3737.

(22) Wiberg, K. B.; Snoonian, J. R. *J. Org. Chem.* **1998**, *63*, 1390, 1402.

(23) Seidl, E. T.; Schaefer, H. F., III. *J. Am. Chem. Soc.* **1991**, *113*, 1915.

(24) Minyaev, R. M.; Minkin, V. I.; Gribanova, T. N.; Starikov, A. G.; Hoffmann, R. *J. Org. Chem.* **2003**, *68*, 8588.

(25) Collins, J. B.; Dill, J. D.; Jemmis, E. D.; Apeloig, Y.; Schleyer, P. v. R.; Seeger, R.; Pople, J. A. *J. Am. Chem. Soc.* **1976**, *98*, 5419.

(26) McGrath, M. P.; Radom, L. *J. Am. Chem. Soc.* **1993**, *115*, 3320.

(27) Lyons, J. E.; Rasmussen, D. R.; McGrath, M. P.; Nobes, R. H.; Radom, L. *Angew. Chem.* **1994**, *106*, 1722.

(28) Rasmussen, D. R.; Radom, L. *Angew. Chem.* **1999**, *111*, 3052.

(29) Radom, L.; Rasmussen, D. R. *Pure Appl. Chem.* **1998**, *70*, 1977.

atoms.^{2–9,30} A few recent examples of nonclassical structures containing ptCs are shown in compounds **10–18**. Some of these are theoretical predictions; some realized kinetically persistent compounds.

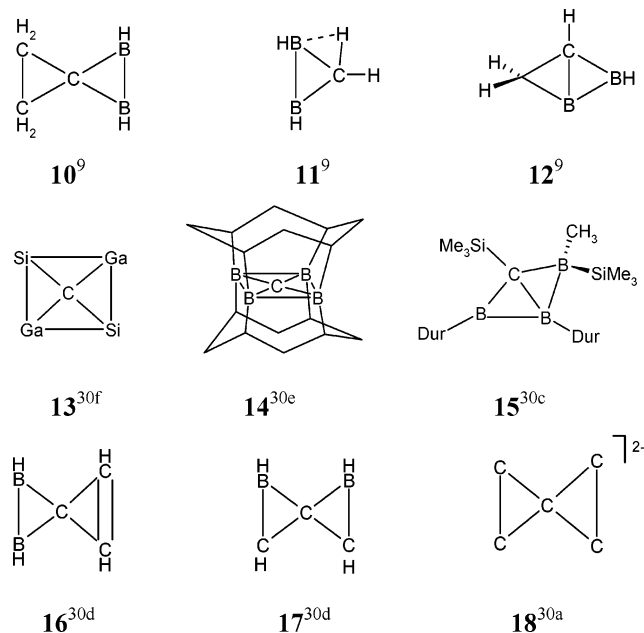

Pyramidalization of ptC centers (**2**→**3**) is usually a stabilizing deformation.³¹ However, instances where this type of distortion leads to a stable molecule with a tetracoordinate pyramidal carbon are restricted to the archetypal pyramidane ([3.3.3]fenestrane) **19**^{3,32} and its derivatives, e.g., **20**¹³ and **21**.³³

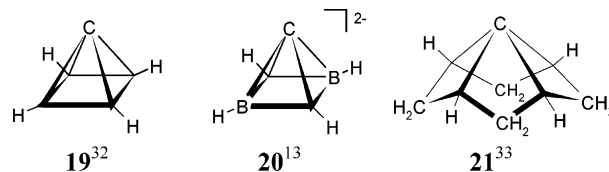

This paper pursues the computational design of novel types of nonclassical organic compounds containing one

(30) (a) Merino, G.; Mendez-Rojas, M. A.; Vela, A. *J. Am. Chem. Soc.* **2003**, *125*, 6026. (b) Huang, J.-H.; Luci, J. J.; Lee, T.-Y.; Swenson, D. C.; Jensen, J. H.; Messelr, L. *J. Am. Chem. Soc.* **2003**, *125*, 1688. (c) Sahin, Y.; Präsang, C.; Hofmann, M.; Subramanian, G.; Geiseler, G.; Massa, W.; Berndt, A. *Angew. Chem., Int. Ed.* **2003**, *42*, 671. (d) Gribanova, T. N.; Minyaev, R. M.; Minkin, V. I. *Collect. Czech. Chem. Commun.* **1999**, *64*, 1780. (e) Wang, Z.-X.; Schleyer, P. v. R. *J. Am. Chem. Soc.* **2001**, *123*, 994. (f) Boldyrev, A. I.; Simons, J. *J. Am. Chem. Soc.* **1998**, *120*, 7967. (g) Pancharatna, P. D.; Mendez-Rojas, M. A.; Merino, G.; Vela, A.; Hoffmann, R. *J. Am. Chem. Soc.* **2004**, *126*, 15309. (h) Priyakumar, U. D.; Sastry, G. N. *Tetrahedron Lett.* **2004**, *45*, 1515. (i) Li, S. D.; Ren, G. M.; Miao, C. Q. *J. Phys. Chem. A* **2005**, *109*, 259. (j) Li, S. D.; Ren, G. M.; Miao, C. Q.; Jin, Z. H. *Angew. Chem., Int. Ed.* **2004**, *43*, 1371. (k) Li, S. D.; Miao, C. Q.; Guo, J. C.; Ren, G. M. *J. Am. Chem. Soc.* **2004**, *126*, 16227. (l) Perez, N.; Heine, T.; Barthel, L.; Seifert, G.; Merino, G.; Mendez-Rojas, M. A.; Beltran, H. I.; Corminboeuf, C.; Heine, T.; Vela, A. *J. Am. Chem. Soc.* **2004**, *126*, 16160. (m) Vela, A.; Mendez-Rojas, M. A.; Merino, G. *Org. Lett.* **2005**, *7*, 1509.

(31) Minkin, V. I.; Minyaev, R. M.; Zakharov, I. I. *J. Chem. Soc., Chem. Commun.* **1977**, 213.

(32) (a) Minkin, V. I.; Minyaev, R. M.; Zakharov, V. I. *Zhurn. Org. Khim. (Russ.)* **1978**, *14*, 3. (b) Balaji, V.; Michl, J. *Pure Appl. Chem.* **1988**, *60*, 189. (c) Lewars, E. *J. Mol. Struct., THEOCHEM* **1998**, *423*, 173; **2000**, *507*, 165. (d) Kenny, J. P.; Krueger, K. M.; Rienstra-Kiracofe, J. C.; Schaefer, H. F., III. *J. Phys. Chem. A* **2001**, *105*, 7745. (e) Minkin, V. I.; Minyaev, R. M. *Dokl. Russ. Akad. Nauk* **2002**, *385*, 502.

(33) Rasmussen, D. R.; Radom, L. *Chem. Eur. J.* **2000**, *6*, 2470.

or more tetracoordinate planar or pyramidal carbon centers. We also wish to gain further insight into the electronic and steric factors making for the stability of such stereochemically nonstandard species. Previous work in this direction^{2–7,9,11,13,25} revealed that an important structural feature facilitating adoption by a carbon atom of the anti-van't Hoff (square-planar or pyramidal) configuration is the inclusion of carbon into various boron-containing rings and cages. This provides for additional stabilization through ligand–ligand interactions.^{13,30d}

This direction of research is continued in this paper, which also considers the nature of bonding in compounds with planar and pyramidal carbon centers. We also look at the factors defining the energy balance between planar and pyramidal configurations of carbon atoms, depending on the number and the ordering of ligating boron atoms.

Computational Methods

The density functional theory (hereafter abbreviated as DFT)³⁴ calculations were carried out by the restricted Hartree–Fock method using the Gaussian 98 system of programs^{35a} with the 6-311+G** basis set. Becke's three-parameter hybrid functional with the Lee–Yang–Parr correlation functional (B3LYP)^{35b–d} was used in the DFT calculations. All the structures corresponding to the stationary points on the respective potential energy surfaces (PES) were optimized until the maximum Cartesian gradient was less than 10^{-5} hartrees bohr⁻¹ (key word “tight”). Analytic harmonic frequencies at the same level of approximation were used to characterize the nature of the stationary point corresponding to the structure under study and to evaluate zero-point energy correction (ZPE). Ab initio calculations carried out by the restricted Hartree–Fock method, including correlation of all electrons (key word “full” in Gaussian 98) according to a second-order Møller–Plesset scheme, gave results not differing in essence from DFT calculations. Those calculations are not presented in the text but are available in Supporting Information. Orbital diagrams were constructed with the EHMO method,³⁶ as incorporated in the CACAO³⁷ program. Molecular structure images presented herein were obtained using the program package GaussView,³⁸ with the final Cartesian coordinates of atoms obtained in the optimization process as the input.

Results and Discussion

1. Building Blocks. The previously studied simple systems **11**,⁹ **16**, and **17**^{13,30d} and the new **22** (derived by removing two hydrogens from **17**) will serve us as building blocks for the rational design of various electri-

(34) Foresman, J. B.; Frisch, E. *Exploring Chemistry with Electronic Structure Methods*, 2nd ed.; Gaussian, Inc.: Pittsburgh, 1996.

(35) (a) Frisch, M. J.; Trucks, G. W.; Schlegel, H. B.; Scuseria, G. E.; Robb, M. A.; Cheeseman, J. R.; Zakrzewski, V. G.; Montgomery, J. A., Jr.; Stratmann, R. E.; Burant, J. C.; Dapprich, S.; Millam, J. M.; Daniels, A. D.; Kudin, K. N.; Strain, M. C.; Farkas, O.; Tomasi, J.; Barone, V.; Cossi, M.; Cammi, R.; Mennucci, B.; Pomelli, C.; Adamo, C.; Clifford, S.; Ochterski, J.; Petersson, G. A.; Ayala, P. Y.; Cui, Q.; Morokuma, K.; Malick, D. K.; Rabuck, A. D.; Raghavachari, K.; Foresman, J. B.; Cioslowski, J.; Ortiz, J. V.; Stefanov, B. B.; Liu, G.; Liashenko, A.; Piskorz, P.; Komaromi, I.; Gomperts, R.; Martin, R. L.; Fox, D. J.; Keith, T.; Al-Laham, M. A.; Peng, C. Y.; Nanayakkara, A.; Gonzalez, C.; Challacombe, M.; Gill, P. M. W.; Johnson, B. G.; Chen, W.; Wong, M. W.; Andres, J. L.; Head-Gordon, M.; Replogle, E. S.; Pople, J. A. *Gaussian 98*, revision A.9; Gaussian, Inc.: Pittsburgh, PA, 1998. (b) Becke, A. D. *Phys. Rev.* **1988**, *38*, 3098. (c) Lee, C.; Yang, W.; Parr, R. G. *Phys. Rev. B* **1988**, *37*, 785. (d) Stevens, P. J.; Devlin, J. F.; Chabalowski, J. F.; Frisch, M. J. *J. Phys. Chem.* **1994**, *98*, 11623.

(36) Hoffmann, R. *J. Chem. Phys.* **1963**, *39*, 1397.

(37) Mealli, C.; Proserpio, D. M. *J. Chem. Educ.* **1990**, *67*, 399.

(38) *GaussView 2.1*; Gaussian, Inc.: Pittsburgh.

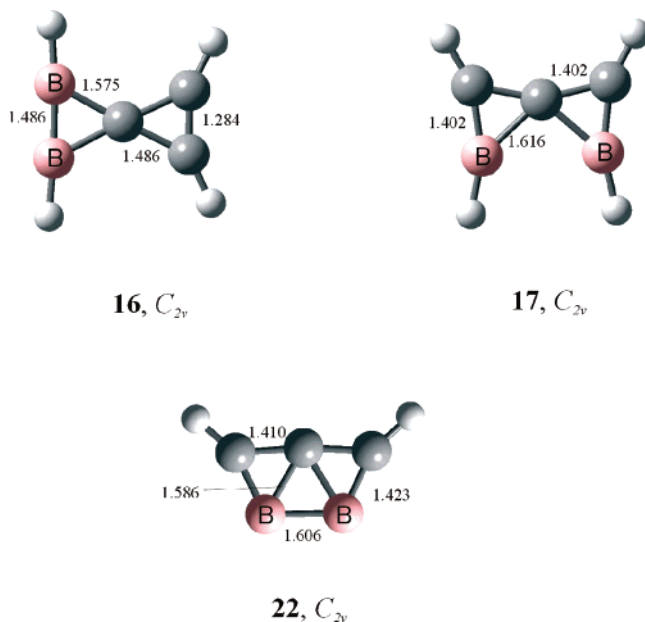
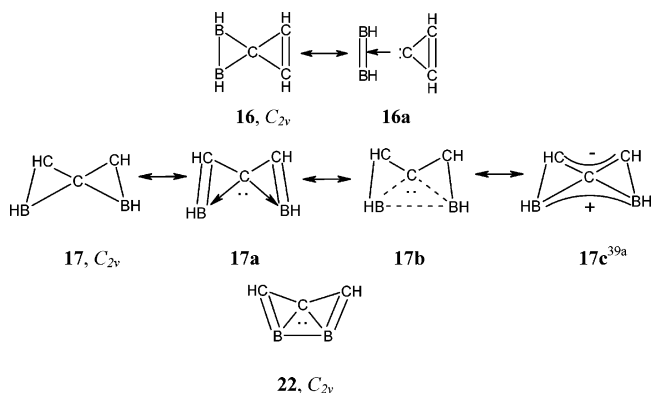

FIGURE 1. Geometries of the planar compounds **16**, **17**, and **22** corresponding to the minima on the respective PESs calculated by the B3LYP/6-311+G** method. The bond lengths are indicated in Ångström units.

cally neutral compounds containing ptC atoms. The molecular structures of **16**, **17**, and **22** calculated by the B3LYP/6-311+G** method are shown in Figure 1.

In molecule **16** we have a very short B–B bond (even shorter than that calculated in HB=BH, 1.523 Å); in **17**, the corresponding BC bond length of 1.402 Å is only slightly longer than that calculated in H₂C=BH (1.376 Å) and substantially shorter than a typical CB bond single bond (1.554 Å) in H₃C–BH₂. Throughout this paper, we are faced with an insoluble problem, one that becomes immediately apparent here: how to describe with symbols derived from a heritage of classical CC bonding novel types of bonding that are inherently nonclassical.



Our tentative proposal is that **16** can be viewed as an internal π -complex^{30m} (**16a**) between a cyclopropenyldiene and a double BB bond. This bonding perspective is analyzed in Figure 2. One of its important features is that it explains the very short BB bond, by partial population of the second π -system of HB=BH.

The bonding situation in **17** is hard to summarize by a single symbol (**17a–c** represent attempts), but it also has elements of carbene complexation. Consider the

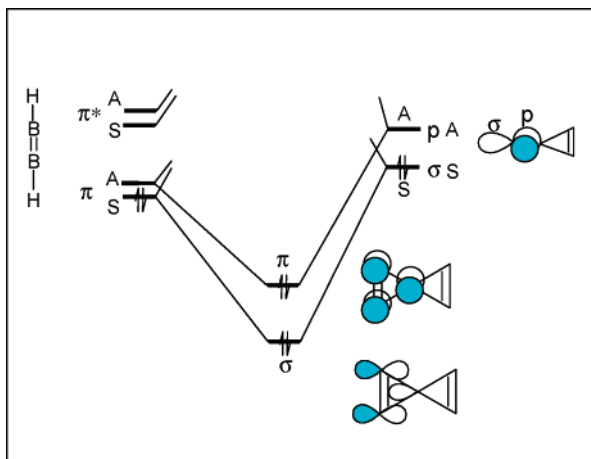
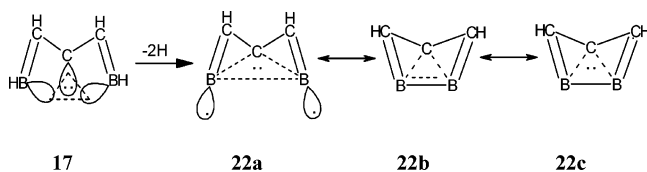

FIGURE 2. Schematic interaction diagram for a cyclopropenyldiene (right) interacting with a linear HBBH (left). Orbitals are labeled as symmetric (S) or antisymmetric (A) with respect to a horizontal mirror plane.

starting point of a carbene linked to two HC=BH units. The σ -system of this molecule is clearly set up for a three-center, two-electron σ -bond. Two π -orbitals are also occupied. The bonding scheme suggested implies some B \cdots B bonding. The relevant distance is actually quite long, at 2.40 Å.

One way to approach the electronic structure of **22** is to take **17** and remove two hydrogens from it, to form a hypothetical **22a**. The two radical lobes at B in **22a** can then form a B–B bond. The B–B distance in **22** is typical of a single B–B bond (1.629 Å calculated for H₂B–BH₂). **22b** and **22c** try to describe the nonclassical bonding pattern that results.



We also see a relationship between the bonding here and that in a fascinating ditantalum propynylidene complex, **23**.^{39b}

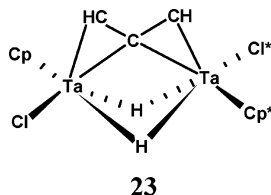

What are the factors stabilizing these molecules? Clearly three-center, two-electron σ - and π -MO systems are attained. Each of the two occupied π -orbitals of **16** is located in one of the three-membered rings, and its shape within each ring (Figure 3) is similar to the occupied π -orbital of an aromatic cyclopropenium cation. Strong

(39) (a) Resonance structure **17c** was proposed by a reviewer. (b) Huang, J.-H.; Luci, J. J.; Lee, T.-Y.; Swenson, D. C.; Jensen, J. H.; Messerle, L. *J. Am. Chem. Soc.* **2003**, *125*, 1688. (c) Minkin, V. I.; Minyaev, R. M.; Dorogan, I. V. *J. Mol. Struct., THEOCHEM* **1997**, *398–399*, 37.

interligand interaction between the peripheral boron centers of **22** serves as a complementary stabilizing effect operating in this compound.

2. Building Up More Complex ptC Molecules.

Structural units **11**, **16**, and **17** can be used as building blocks for the construction of more complex organoboron systems with one, two, and three ptCs, whose structures are pictured in Figure 4. In general, lines in our drawings represent a provisional bonding assignment based in part on calculated bond lengths, in part on simple bonding formalisms.

Stabilization of the borabenzenes **24**, **30**, and **31** containing ptC centers is achieved through the same type of bonding as in the parent system **16**, whereas for **26** the bonding closely resembles that of **17** (compare the shape of the occupied π -orbitals in Figures 3 and 5).

Because of the very unsymmetrical bonding environment of the ptC, one of the CB bonds in compounds **24** and **26** is markedly elongated compared with **16**. Non-classical structure **24**, containing a ptC center, is computed to be preferred in energy compared to its isomer **25**.

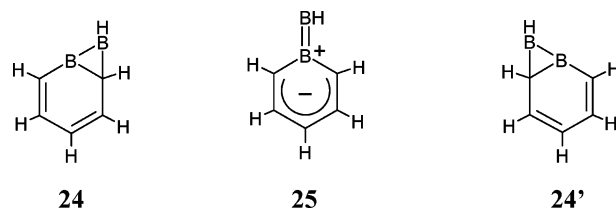

Analogously, according to the DFT calculations, non-classical structures **26** are lower in energy than **27** (the Lewis structure of which is drawn according to the calculated charge distribution), which is the transition state for the rearrangement^{39c} **26** \rightleftharpoons **27** \rightleftharpoons **26'**. It is worth noting that the geometry of the triangle fragments including ptC centers in **26** closely resembles that of **12**.⁹

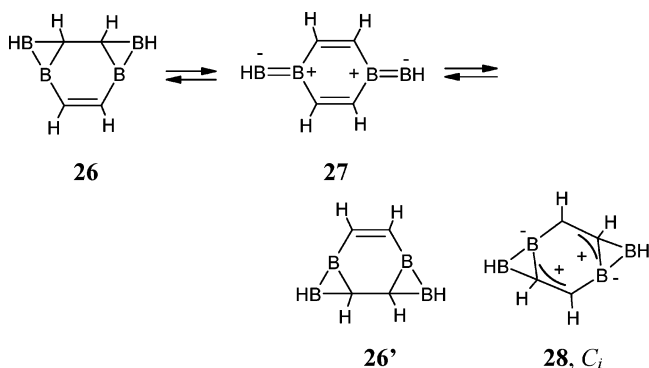

We note that the diboron-bridged compound **26** also has a trans isomer **28**, which is 7.3 kcal/mol less stable than the cis form.

The lengths of the CB bonds in compounds **26**, **28**, **29**, and **31** are typical of ordinary CB bonds, and are close to experimentally determined CB bond lengths in boratabenzene anion (1.514 Å⁴⁰) and 1,4-difluoro-1,4-dibo-

(40) Herberich, G. E.; Schmidt, B.; Unglert, U.; Wagner, T. *Organometallics* **1993**, *12*, 2891.

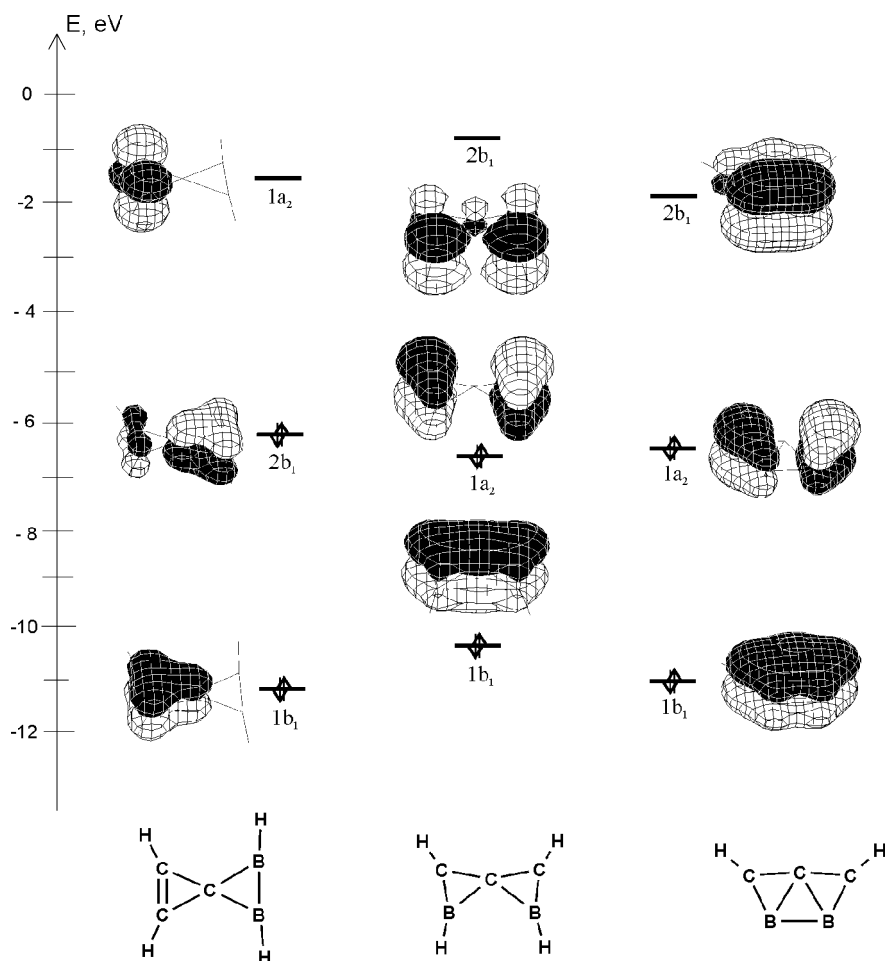
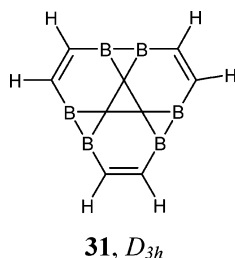

FIGURE 3. π -Orbitals of planar systems **16**, **17**, and **22**. Energy levels were calculated by the B3LYP/6-311+G** method.

rabenzene (1.571 \AA^{41}). In **30**, the distance between the boron and carbon atoms incorporated into the six-membered ring (1.639 \AA) is some 0.09 \AA longer than a normal CB bond. In the DFT calculations the less symmetrical isomer **29** is slightly (1 kcal/mol) preferred to **30**.

The stability of the highly symmetrical structure **31** with three ptC centers within a molecule is closely associated with aromatic character of the internal C_3 -ring. The total Mulliken charge of this ring is $+1.2 e$.



As seen in Figure 5, the frontier orbitals in the systems **24**, **26**, **30**, and **31** are π -type orbitals, and these compounds are characterized by substantial HOMO–LUMO gaps.

(41) (a) Onak, T.; Diaz, M.; Barfield, M. *J. Am. Chem. Soc.* **1995**, *117*, 1403. (b) Vaddren, P. S.; Modinos, A.; Timms, P.; Woodward, P. *J. Chem. Soc., Dalton Trans.* **1975**, 1272. (c) Timms, P. L. *J. Am. Chem. Soc.* **1968**, *90*, 4585

The basic structural units **17** and **22** may be used, in an analogous way, to construct another group of compounds, **32–36**, containing ptC centers. Their geometrical parameters are presented in Figure 6.

The carbon-containing, six-membered rings in **32** and **33** and the eight-membered ring in **34** are computed to be strictly planar, and the lengths of the CC bonds are close in value to those typical for CC_{arom} bonds. Compounds **35** and **36** are examples of various ways of integrating several (in our case two) basic ptC blocks **22** in a common system. The geometrical parameters of the compounds formed are affected in only minor ways; the nature of bonding supporting the ptC centers does not change. The trans isomer **36'** is 0.26 kcal/mol more stable compared to its cis counterpart **36**.

The stability of the nonclassical structures considered above was determined by a combination of electronic and steric effects, including (a) surrounding the atom with π -withdrawing and σ -releasing groups, (b) inclusion of carbon into strained three-membered aromatic rings, and (c) strong interligand attractive interactions between the peripheral ligating centers.

Removal of any of these contributing factors, or significant weakening of some of these, leads to deformation from planarity at the tetracoordinate carbon centers. In general, the distortions are associated with structural relaxation in the direction of tetrahedral forms, but in some cases, as we will see, they may lead to the formation

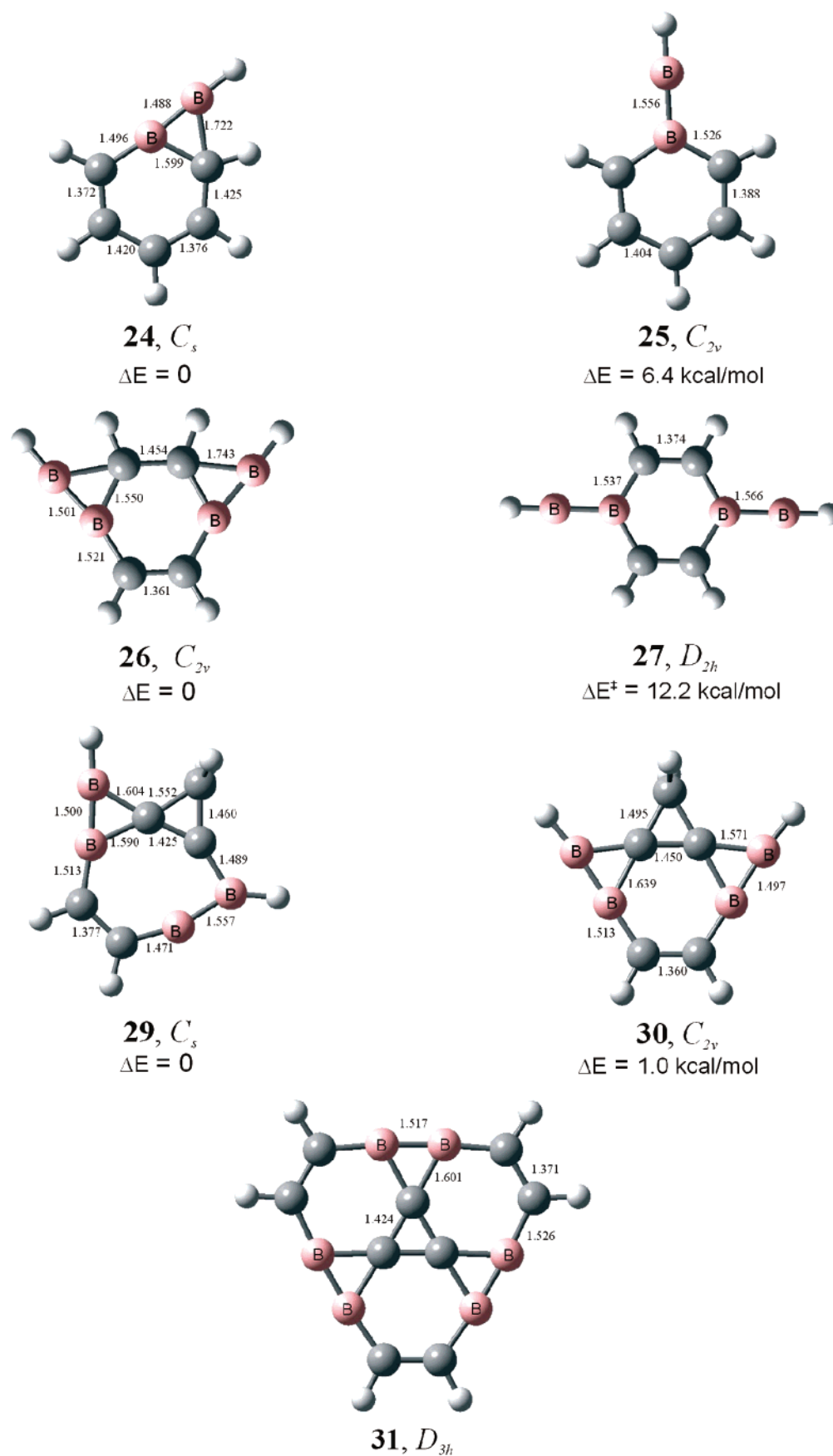

FIGURE 4. Geometrical parameters of planar compounds **24–26** and **29–31**, minima, and **27**, a transition state, on the respective PESs calculated by the B3LYP/6-311+G** method. The bond lengths are indicated in Ångström units.

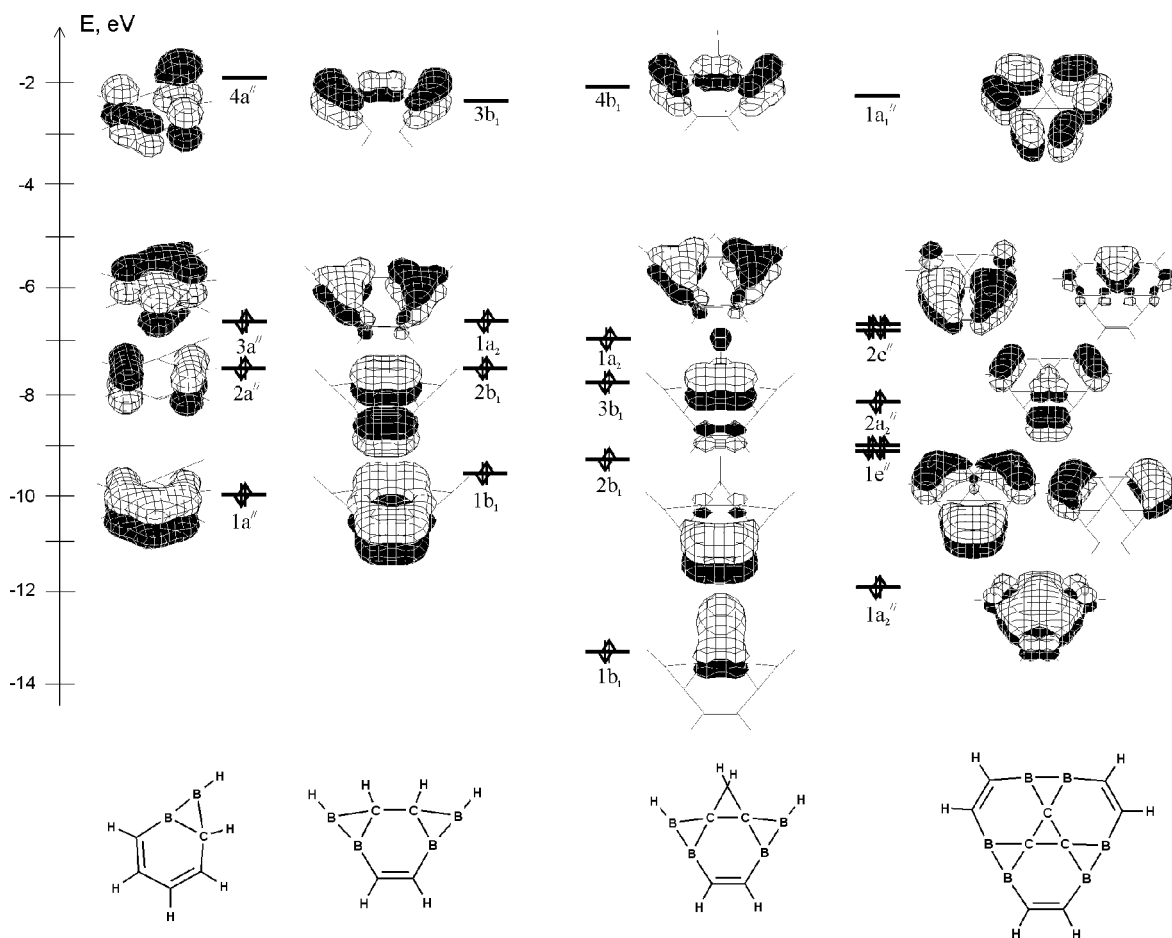
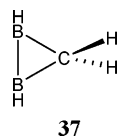

FIGURE 5. π -Orbitals of planar systems **24**, **26**, **30**, and **31**. Energy levels are calculated by the B3LYP/6-311+G** method.

of compounds with the rather rare square pyramidal configuration of bonds.

3. Tetracoordinate Pyramidal Carbon. If in structure **16** one three-membered ring is removed through substitution of the C–C double bond by two hydrogen atoms, diboracyclopropane **37** is produced. This molecule is not a minimum on its PES and converts to planar **38**.



However, in accordance with earlier findings,⁹ DFT calculations showed that **38** is also not a minimum but serves as the transition state for the rearrangement **11** ⇌ **38** ⇌ **11'**. The most stable isomer is **39**, which is more energetically favorable than **11** by 30 kcal mol. The calculated geometries of **38** and **39** are given in Figure 7.

Inserting a methylene group into the B–B bond leads to 1,3-diboracyclobutane, the four-membered ring of which adopts a puckered conformation **40** with two classical tetrahedral carbon centers (Figure 7).^{2,3} Interestingly, there is a relatively low barrier to twisting one methylene group in this molecule; the transition state for this kind of “inversion” of one C in **40** is **41**, slightly pyramidal (deviation of the CH bonds from the BBC

plane is about 5°, Figure 7), and requires overcoming of a comparatively low energy barrier (~27 kcal/mol).

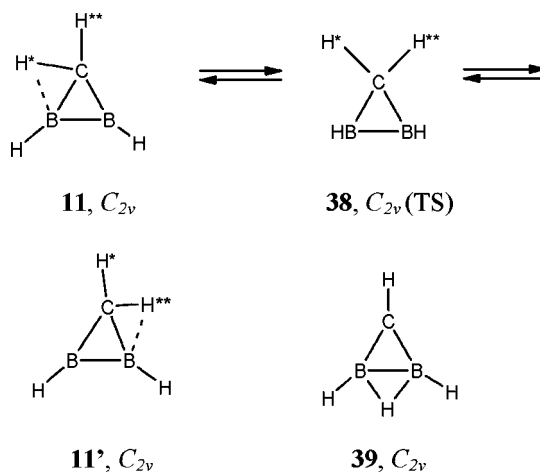

For calibration, the barrier to inversion of the tetrahedral carbon in methane was calculated to be more than 100 kcal mol,^{5–7,10} which exceeds the energy of cleaving of a CH bond. There are no computed isomers of **40** with a strictly planar configuration of bonds at the tetracoordinate carbon. The peripheral ring in **40** is important for stabilization of the pyramidal tetracoordinate carbon. No energy minima on the respective PESs corresponding to structures with a planar or pyramidal tetracoordinate

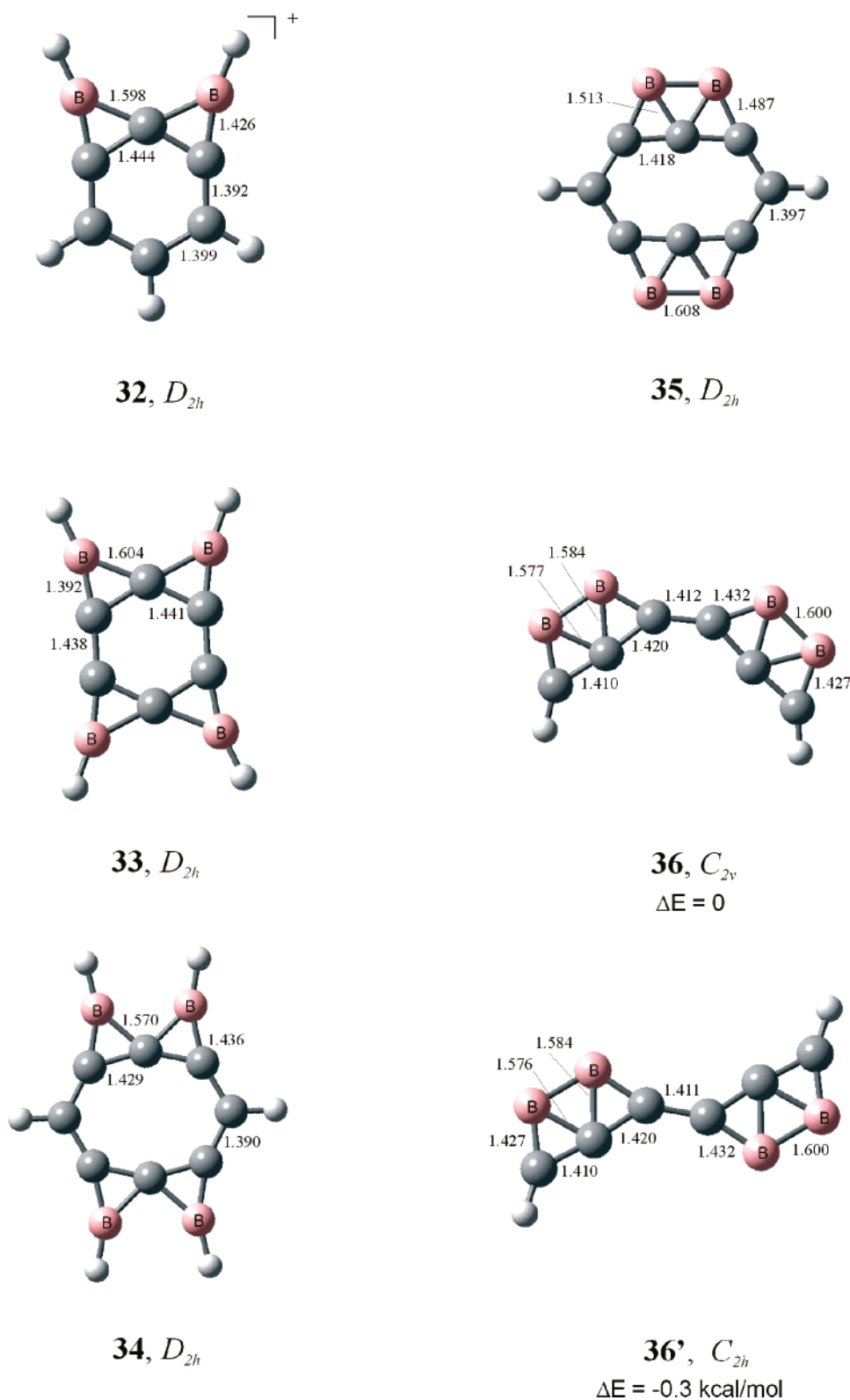

FIGURE 6. Geometries of the planar compounds **32**–**36** corresponding to minima on the respective PESs calculated by the B3LYP/6-311+G** method. The bond lengths are indicated in Ångström units.

carbon were found⁴³ for the acyclic diborylmethane $\text{CH}_2\text{-(BH}_2)_2$ or tetraborylmethane $\text{C(BH}_2)_4$.

(42) Balakrishnarajan, M. M.; Hoffmann, R. *J. Am. Chem. Soc.* **2004**, *126*, 13119.

(43) Minyaev, R. M.; Quapp, W.; Subramanian, G.; Schleyer, P. v. R.; Mo, Y. *J. Comput. Chem.* **1997**, *18*, 1792.

In 1,3,5,7-tetraboraspiro[3.3]heptane **42** (Figure 8), two additional boron centers adjacent to the tetracoordinate carbon provide for further stabilization of the unusual pyramidal configuration. The DFT calculations predict that the pyramidal C_{2v} structure **42** (the distance of the central C from the B–B–B–B plane is about 0.3 Å; see

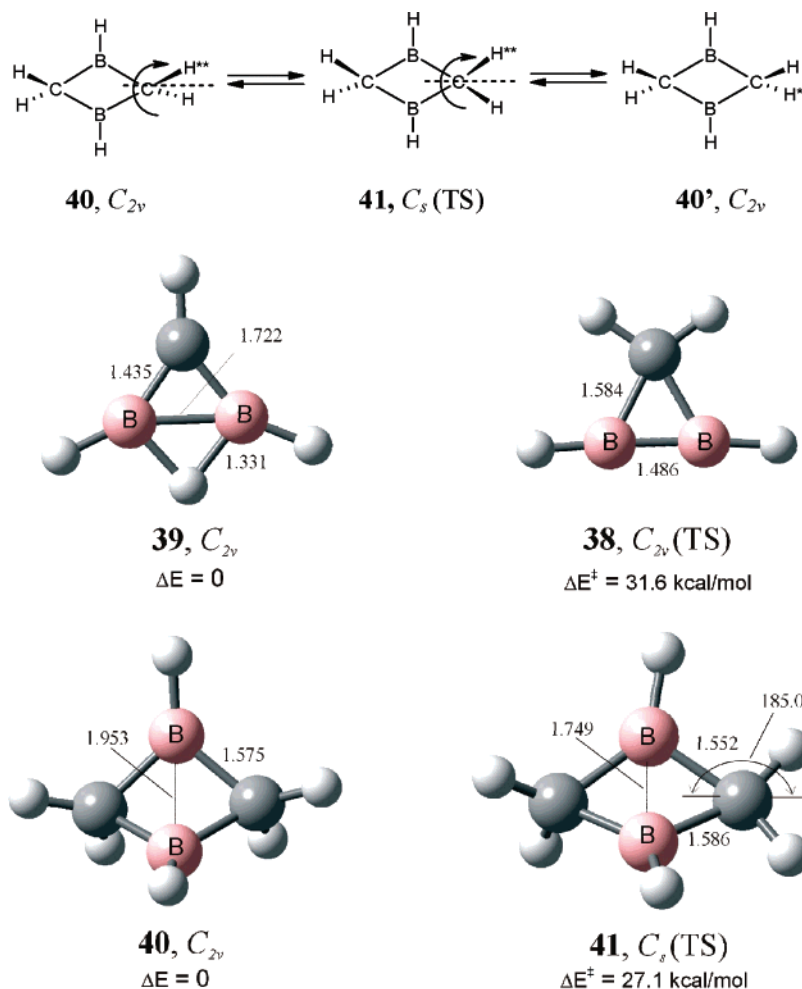

FIGURE 7. Geometries of the planar compounds **39** and **40** corresponding to minima and **38** and **41** corresponding to the saddle points (transition state structures) on the respective PESs calculated by the B3LYP/6-311+G** method. The bond lengths and angles are indicated in Ångström units and degrees, respectively.

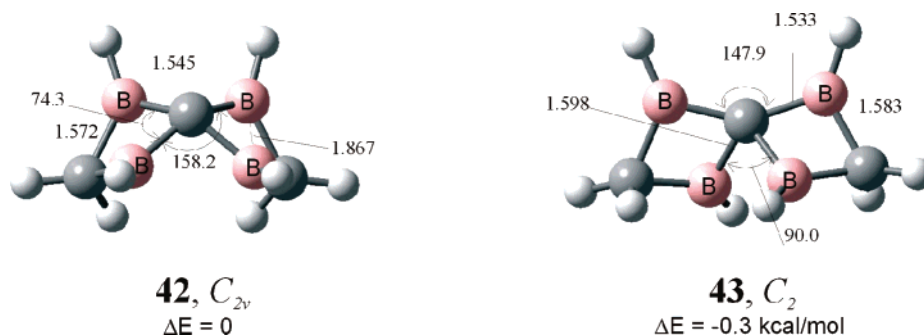
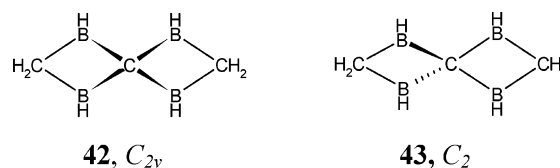

FIGURE 8. Geometric parameters of compounds **42** and **43** corresponding to the minima on the respective PESs calculated by the B3LYP/6-311+G** method. The bond lengths and angles are indicated in Ångström units and degrees, respectively.

also Figure 8) represents a local minimum. Energetically, this structure is nearly equivalent to isomer **43**, which has a tetrahedral, albeit strongly deformed, carbon atom. The two structures are remarkably similar in energy, the DFT method predicts that tetrahedral **43** is only 0.3 kcal/mol lower in energy. By comparison, the D_{2h} structure of 1,3,5,7-tetraboraspiro[3.3]heptane with a ptC atom is characterized by three negative force constants ($\lambda = 3$), and its total energy is about 30 kcal/mol higher than those of structures **42** or **43**.



The relative destabilization of the planar structure may be caused by the loss of stabilizing interligand interactions due to insertion of methylene groups between the boron centers. At the same time, surrounding a carbon

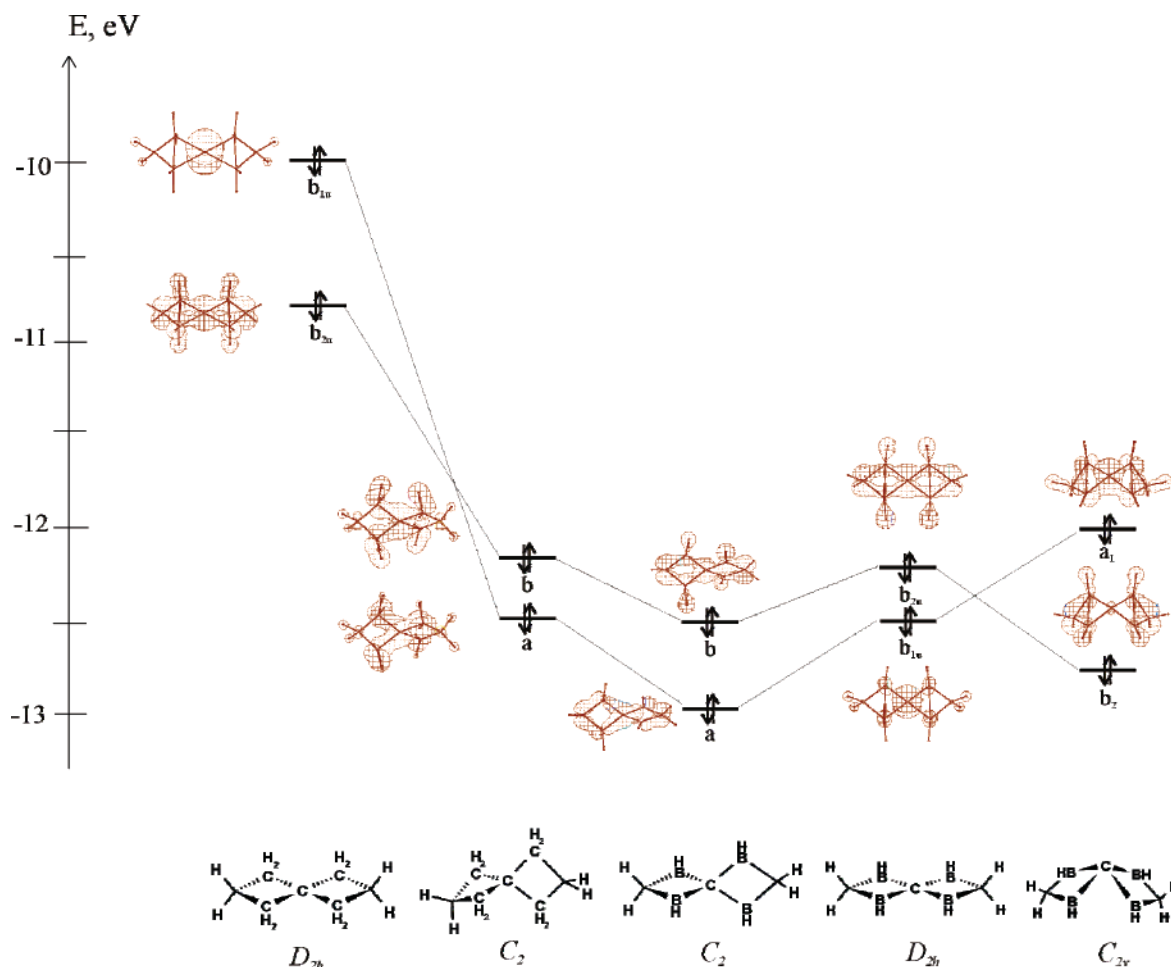

FIGURE 9. CACAO^{36,37} drawing of evolution of the occupied HOMOs of spiro[3,3]heptane and 1,3,5,7-tetraboraspiro[3.3]heptane in various conformations. Energy levels are calculated by the EHMO method.³⁶

atom in **42** by four boron-centered ligands turns out to be sufficient for stabilizing a square pyramidal configuration at the C. The role of the boron environment may be probed through a comparison of the electronic structures of **42** and spiro[3,3]heptane, which is the hydrocarbon analogue of **42**. Both the planar and pyramidal structures of spiro[3,3]heptane are destabilized by about 150 kcal/mol with respect to the standard tetrahedral structure and, moreover, are not local minima on the C₇H₁₂ PES. As may be seen from the orbital diagram in Figure 9, the high energy of the planar form of spiro[3,3]heptane is due to destabilization of the HOMOs (b_{1u} and b_{2u}). One of these, b_{1u} , is a pure p_z -AO of the pC, as in the case of planar methane. Substitution of CH₂ groups by BH groups (**43**) provides for stabilization of HOMOs (b_{1u} and b_{2u}) and consequently leads to a lower energy for the pyramidal and planar forms. As seen in Figure 9, in **42** and **43** the b_{1u} MOs are delocalized over the CB₄ fragments.

Significant additional steric stabilization of the square pyramidal carbon center is achieved in compounds **44** and **45** (Figure 10), through further closing of four-membered 1,3-boron cycles around the central carbon atom of **42**. For carbon analogues, the stable conformations are structures with a (distorted) tetrahedral central carbon,³ such structures do not correspond to the minima on the PESs of either **44** or **45**.

Continuing the exploration of further constraints, we find that the planar D_{4h} conformation of [3.3.3.3]tetraborafenestrane **46** is sterically destabilized with respect to **45** and represents the transition state for the umbrella-like inversion configuration at the square pyramidal tetracoordinate carbon of the latter. The energy barriers for the $\mathbf{45} \rightleftharpoons \mathbf{46} \rightleftharpoons \mathbf{45}'$ interconversion were calculated to be 57.5 kcal/mol.

Searching for further electrically neutral structures with hypercoordinate carbon atoms, we studied computationally systems C(BCH₂)_n with $n = 5$ and 6. In both cases, the optimization process led to structures with square pyramidal tetracoordinate central carbons **47** and **48**, respectively. The geometries of these structures are displayed in Figure 11.

Conclusion

The planar configuration of bonds at tetracoordinate carbon atoms in the simple carboranes **16**, **17**, and **22** is ensured by the cumulative action of all principal electronic and steric factors favoring this nonclassical stereochemistry. Inclusion of a planar carbon into at least one aromatic three-membered ring appears to be mandatory for a stable structure. π -Withdrawing and σ -releasing substituents and strong interligand interactions are also needed. All these stabilizing features are present in

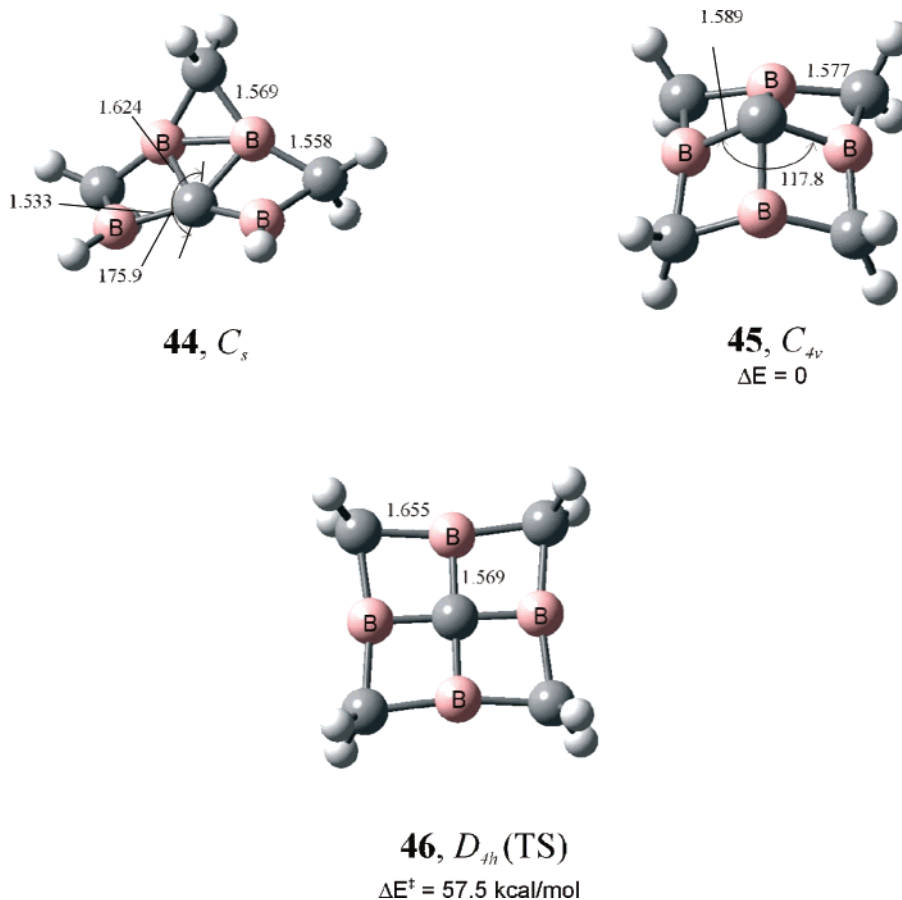

FIGURE 10. Geometric parameters of pyramidal compounds **44** and **45** corresponding to the minima and also structure **46** corresponding to the saddle point (transition state structure) on the respective PESs calculated by the B3LYP/6-311+G** method. The bond lengths and angles are indicated in Ångström units and degrees, respectively.

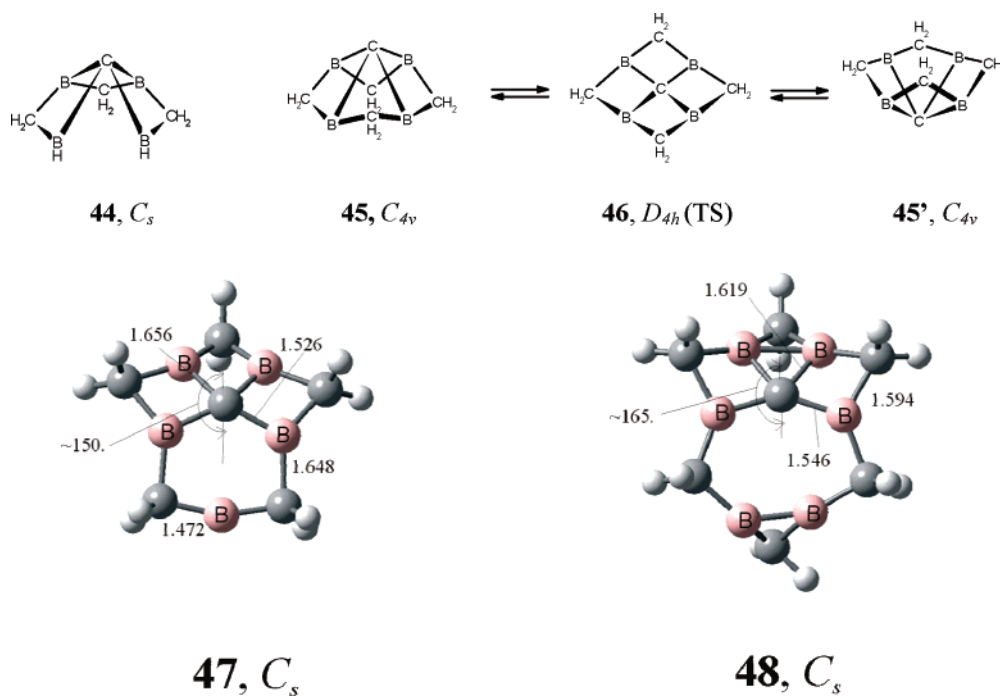

FIGURE 11. Geometric parameters of compounds **47** and **48** corresponding to minima on the respective PESs calculated by the B3LYP/6-311+G** method. The bond lengths and angles are indicated in Ångström units and degrees, respectively.

the structures (**26**, **28**, **30**, and **31**), with two and three planar tetracoordinate carbon centers, which we designed using **16**, **17**, and **22** as versatile building blocks. The requirements found should be kept in mind in thinking about two-dimensional systems with planar tetracoordinate carbon atoms. Less strict are the requirements for stabilization of square pyramidal tetracoordinate carbon centers, which are predicted to be present in compounds **42**, **44**, **45**, **47**, and **48**, where the apical carbon is surrounded by π -accepting and σ -donating basal boron centers.

Acknowledgment. This work was supported by CRDF (Grant RC1-2323-RO-02), Russian Foundation for Basic Research (Grant 04-03-32538), and Ministry of Education and Science of Russian Federation (N. Sh. 945.2003.3).

Supporting Information Available: Total energies, frequencies, and atomic coordinates of optimized structures **16**, **17**, **22**, **24–36**, and **38–48** calculated by the RB3LYP/6-311+G** method. This material is available free of charge via the Internet at <http://pubs.acs.org>.

JO050651J